



GRIP Head office (Jinsung Eurotec co., ltd.)

#817 Daerung technotown 12nd Gasandigital 2 ro 14 Geumcheon-gu Seoul Republic of korea.

GRIP Factory

#b101-201 397 Seckcheon-ro Buchun-si Gyeonggi-do Republic of Korea

Tel.+82 32 624 0907~8

Fax.+82 32 624 0909

gripperfect@gmail.com

www.gripkorea.com



ACCESSORIES

Hydro-line options and spare parts



HYDRO-ACCESSORIES

Hydro-sleeve



Coolant type

Dimensions(mm)

OD8	D1	D2	D3	L1	L2	Kg.
OD8-3	3	8	12.5	35.5	2	0.1
OD8-4	4	8	12.5	35.5	2	0.1
OD8-5	5	8	12.5	35.5	2	0.1
OD8-6	6	8	12.5	35.5	2	0.1

OD12	D1	D2	D3	L1	L2	Kg.
OD12-3	3	12	19	45	2	0.1
OD12-4	4	12	19	45	2	0.1
OD12-5	5	12	19	45	2	0.1
OD12-6	6	12	19	45	2	0.1
OD12-7	7	12	19	45	2	0.1
OD12-8	8	12	19	45	2	0.1
OD12-9	9	12	19	45	2	0.1
OD12-10	10	12	19	45	2	0.1

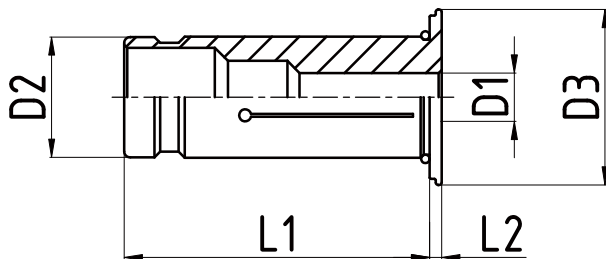

OD8/ OD12/ OD20/ OD32

≡ Dimensions(mm)

OD20	D1	D2	D3	L1	L2	Kg.
OD20-3	3	20	27	50.5	2	0.1
OD20-4	4	20	27	50.5	2	0.1
OD20-5	5	20	27	50.5	2	0.1
OD20-6	6	20	27	50.5	2	0.1
OD20-7	7	20	27	50.5	2	0.1
OD20-8	8	20	27	50.5	2	0.1
OD20-9	9	20	27	50.5	2	0.1
OD20-10	10	20	27	50.5	2	0.1
OD20-11	11	20	27	50.5	2	0.1
OD20-12	12	20	27	50.5	2	0.1
OD20-13	13	20	27	50.5	2	0.1
OD20-14	14	20	27	35.5	2	0.1
OD20-15	15	20	27	35.5	2	0.1
OD20-16	16	20	27	35.5	2	0.1
OD20-17	17	20	27	35.5	2	0.1
OD20-18	18	20	27	35.5	2	0.1

≡ Dimensions(mm)

OD32	D1	D2	D3	L1	L2	Kg.
OD32-3	3	32	39	60.5	2	0.3
OD32-4	4	32	39	60.5	2	0.3
OD32-5	5	32	39	60.5	2	0.3
OD32-6	6	32	39	60.5	2	0.3
OD32-7	7	32	39	60.5	2	0.3
OD32-8	8	32	39	60.5	2	0.3
OD32-9	9	32	39	60.5	2	0.3
OD32-10	10	32	39	60.5	2	0.3
OD32-11	11	32	39	60.5	2	0.3
OD32-12	12	32	39	60.5	2	0.3
OD32-13	13	32	39	60.5	2	0.3
OD32-14	14	32	39	60.5	2	0.3
OD32-15	15	32	39	60.5	2	0.3
OD32-16	16	32	39	60.5	2	0.3
OD32-17	17	32	39	60.5	2	0.3
OD32-18	18	32	39	60.5	2	0.3
OD32-19	19	32	39	60.5	2	0.3
OD32-20	20	32	39	60.5	2	0.2
OD20-25	21	32	39	60.5	2	0.2

- »All shank tools must be used.
- »Internal Coolant type Run-out 3xd 3Micron all items.
- »Additional sizes and special designs available on request.
- »Applied when using oil hole type tools.
- »Recommended for use in precise work.
- »All types of shank can be used.(Stright, Flat, Whistle notch)

HYDRO-ACCESSORIES

Hydro-sleeve



Non Coolant type

Dimensions(mm)

D12	D1	D2	D3	L1	L2	Kg.
D12-3	3	12	19	45	2	0.1
D12-4	4	12	19	45	2	0.1
D12-5	5	12	19	45	2	0.1
D12-6	6	12	19	45	2	0.1
D12-7	7	12	19	45	2	0.1
D12-8	8	12	19	45	2	0.1
D12-9	9	12	19	45	2	0.1
D12-10	10	12	19	45	2	0.1

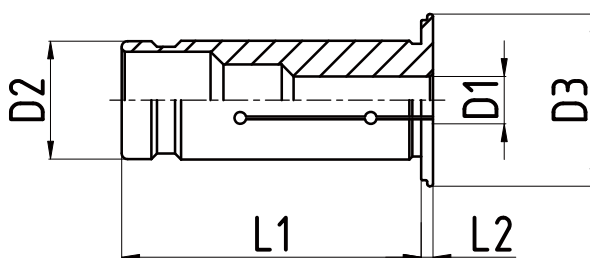

D12/ D20/ D32

≡ Dimensions(mm)

D20	D1	D2	D3	L1	L2	Kg.
D20-3	3	20	27	50.5	2	0.1
D20-4	4	20	27	50.5	2	0.1
D20-5	5	20	27	50.5	2	0.1
D20-6	6	20	27	50.5	2	0.1
D20-7	7	20	27	50.5	2	0.1
D20-8	8	20	27	50.5	2	0.1
D20-9	9	20	27	50.5	2	0.1
D20-10	10	20	27	50.5	2	0.1
D20-11	11	20	27	50.5	2	0.1
D20-12	12	20	27	50.5	2	0.1
D20-13	13	20	27	50.5	2	0.1
D20-14	14	20	27	35.5	2	0.1
D20-15	15	20	27	35.5	2	0.1
D20-16	16	20	27	35.5	2	0.1
D20-17	17	20	27	35.5	2	0.1
D20-18	18	20	27	35.5	2	0.1

≡ Dimensions(mm)

D32	D1	D2	D3	L1	L2	Kg.
D32-3	3	32	39	60.5	2	0.3
D32-4	4	32	39	60.5	2	0.3
D32-5	5	32	39	60.5	2	0.3
D32-6	6	32	39	60.5	2	0.3
D32-7	7	32	39	60.5	2	0.3
D32-8	8	32	39	60.5	2	0.3
D32-9	9	32	39	60.5	2	0.3
D32-10	10	32	39	60.5	2	0.3
D32-11	11	32	39	60.5	2	0.3
D32-12	12	32	39	60.5	2	0.3
D32-13	13	32	39	60.5	2	0.3
D32-14	14	32	39	60.5	2	0.3
D32-15	15	32	39	60.5	2	0.3
D32-16	16	32	39	60.5	2	0.3
D32-17	17	32	39	60.5	2	0.3
D32-18	18	32	39	60.5	2	0.3
D32-19	19	32	39	60.5	2	0.3
D32-20	20	32	39	60.5	2	0.2
D32-25	21	32	39	60.5	2	0.2

- »All shank tools must be used.
- »Internal Coolant type Run-out 3xd 5Micron all items.
- »Additional sizes and special designs available on request.
- »All types of shank can be used.(Stright, Flat, Whistle notch)

HYDRO-ACCESSORIES

Coolant Tube

Coolant Tube is for optimum internal supply of HSK holder.
It prevents spindle from being spoiled and rests the sealing system.



≡ Dimensions(mm)

CT	For		D1	L1	L2	G
CT40	HSK32	●	8.0	7.5	29.0	M12x1
CT50	HSK40	●	10.0	9.5	33.0	M16x1
CT63	HSK63	●	12.0	11.5	36.5	M18x1
CT100	HSK100	●	16.0	15.0	43.5	M24x1.5

Availability: ● Stock ▲ Short lead time ○ Made to order

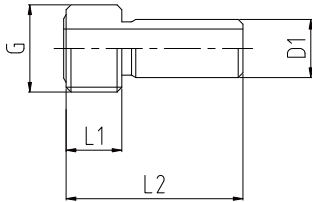

Coolant Tube

Coolant Tube Wrench



≡ Dimensions(mm)

CTR	For		D1	D2	L1
CTR40	HSK32	●	8.0	11.0	111.0
CTR50	HSK40	●	10.0	15.0	120.0
CTR63	HSK63	●	12.0	17.0	122.0
CTR100	HSK100	●	16.0	22.0	141.0

Availability: ● Stock ▲ Short lead time ○ Made to order

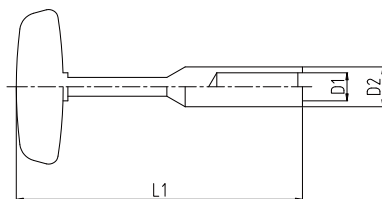

Coolant Tube Wrench

Torque T-wrench (5.5Nm)



TR		Applied product
TR-4.0	4mm	ID 6/8/10/12/14/16/18
TR-5.0	5mm	ID 20/25/32

- »5.5Nm torque.
- »Extended hydraulic piston and parts life.
- »Capable of clamping with constant force.

T-wrench



T			length
T-2.5	●	2.5	100
T-3.0	●	3	100
T-4.0	●	4	100
T-5.0	●	5	100
T-6.0	●	6	100

Availability: ● Stock ▲ Short lead time ○ Made to order

Setting BAR

The setting bar is very precise. It is used for accurate run-out setting when used as a HYDRO-CENTRO.



STB	Applied product
STB-3/ 4/ 6/ 8/ 10/ 12	ID 3/4/6/8/10/12

HYDRO-ACCESSORIES

Data Carrier

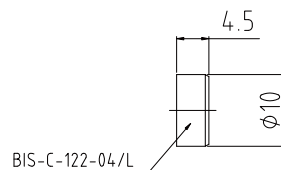

Data Carrier

≡ Dimensions(mm)

DTC10	
Dimensions	10x4.5mm
Housing material	Poly-A
Storing capacity	511 Byte
Matching reading and writing head	BIS-C-300/302/305/306/325
Max. reading/writing head	2.5mm
Mode of installation	Flush mounted
Min./Max. ambient temperature	0 / -70°C
Min./Max. stocking temperature	0 / -70°C
Protection class as per DIN 40050	IP 67
Programming cycles	500000 (<70°C)
Read cycles	Unlimited

ID Cleaner



Pic1

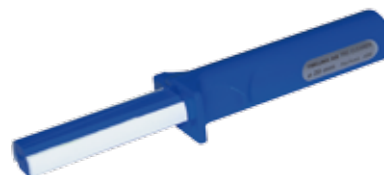

Pic2

Hydraulic chuck inner diameter oil removal cleaning tool.

IC	Pic.	Applied product
IC-6/ 8/ 10/ 12/ 14	Pic1	ID 6/8/10/12/14
IC-16/ 18/ 20/ 25/ 32	Pic2	ID 16/18/20/25/32

Spare Part (Screw)

Adjustment screws

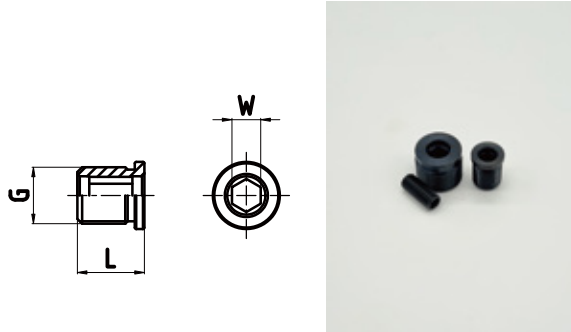

Dimensions(mm)

AJS	G	L	W
AJS-M5	M5x0.8	14	2.5
AJS-M6	M6x1.0	14	3.0
AJS-M8	M8x1.0	14	4.0
AJS-M10	M10x1.0	14	5.0
AJS-M12	M12x1.0	14	6.0
AJS-M16	M16x1.0	14	6.0

Clamping screw

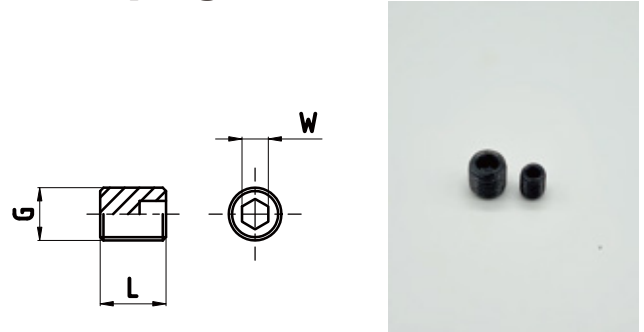

Dimensions(mm)

CS	G	L	W
CS-M8	M8x1.25	14	4.0
CS-M10	M10x1.5	14	5.0

ZERO-FIT setting screw

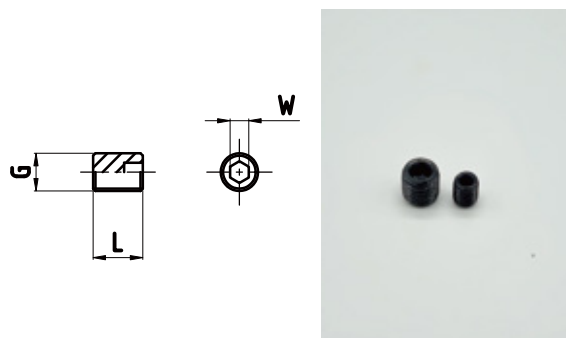

Dimensions(mm)

ZSS	For	G	L	W
ZSS-M4	ID-6,8	M4x0.7	8	2.0
ZSS-M6	ID-10~32	M6x1.0	8	3.0