



GRIP Head office (Jinsung Eurotec co., ltd.)

#817 Daerung technotown 12nd Gasandigital 2 ro 14 Geumcheon-gu Seoul Republic of korea.

GRIP Factory

#b101-201 397 Seckcheon-ro Buchun-si Gyeonggi-do Republic of Korea

Tel.+82 32 624 0907~8

Fax.+82 32 624 0909

gripperfect@gmail.com

www.gripkorea.com

HYDRO-GRIND

Tool Grinding and Sharpening.

New!!

More Various product line-up



HYDRO-GRIND

≡ A wide range of products from 6 to 32 bore diameters.

Optimization of work precision by direct fastening of workpieces.

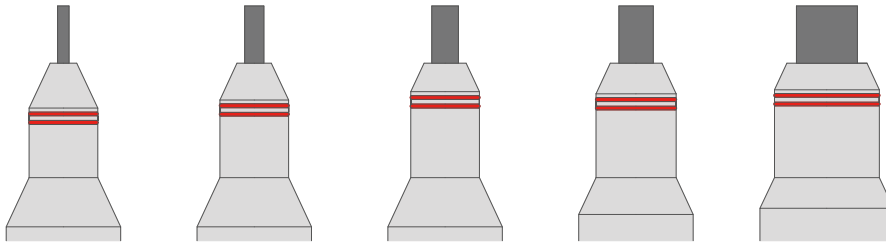

ID12, ID20, ID32 Hydro-sleeve can be used.

≡ Always keep the same run-out.

Standard run-out $3 \times 3 \mu\text{m}$.

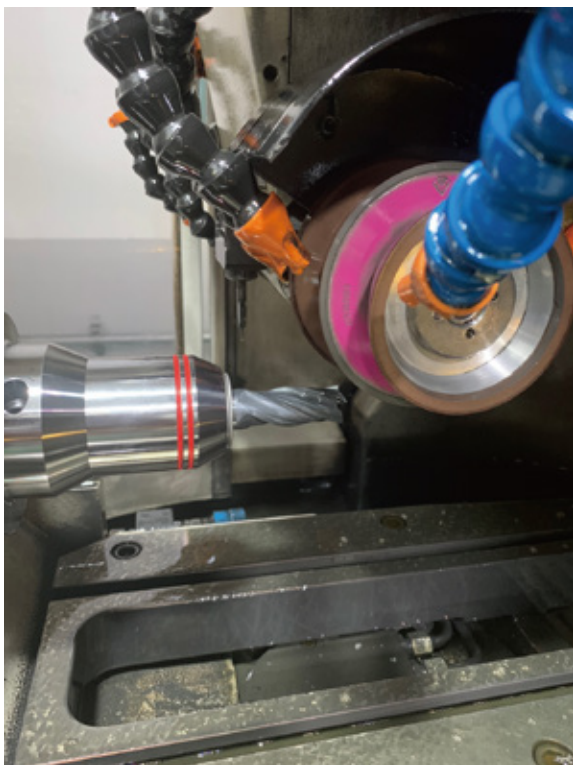
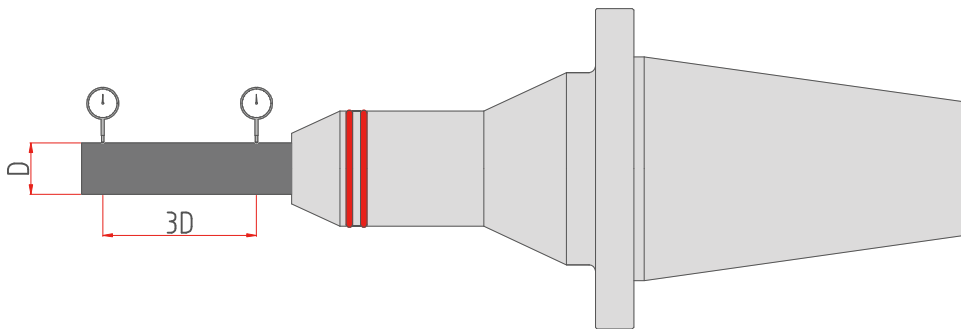

≡ Minimized wheel interference at an inlet angle of 25 degrees.

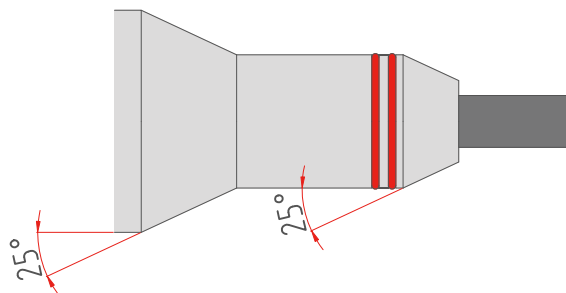

Dimensions(mm)

VBT		D1	D2	D3	D4	L1	L2	L3	L4	Clamping wrench	Adjustment bolt (wrench)	Kg.
VBT50/GR6/110	●	6	14	36	60	110	-	27.5	60	TR-4.0	-	3.6
VBT50/GR8/110	●	8	16	36	60	110	-	27.5	60	TR-4.0	-	3.6
VBT50/GR10/110	●	10	18	36	60	110	-	32.5	60	TR-4.0	-	3.6
VBT50/GR12/110	●	12	20	36	60	110	-	37.5	60	TR-4.0	-	3.6
VBT50/GR14/110	●	14	22	36	60	110	-	37.5	60	TR-4.0	-	3.7
VBT50/GR16/110	●	16	24	40	60	110	-	42.5	60	TR-4.0	-	3.7
VBT50/GR18/110	●	18	27	42	60	110	-	42.5	60	TR-4.0	-	3.8
VBT50/GR20/110	●	20	29	45	60	110	-	42.5	60	TR-5.0	-	3.8
VBT50/GR25/110	●	25	34	50	70	110	-	51	60	TR-5.0	-	3.9
VBT50/GR32/110	●	32	42	55	70	110	-	55	60	TR-5.0	-	4.0

Availability: ● Stock ▲ Short lead time ○ Made to order

- »h6 shank tools must be used.
- »Deep insertion depth.
- »T-wrench is must be ordered separately.
(GRIP torque wrench is recommended.)
- »Additional sizes and special designs available on request.
- ⚠ The minimum tool depth must be observed.

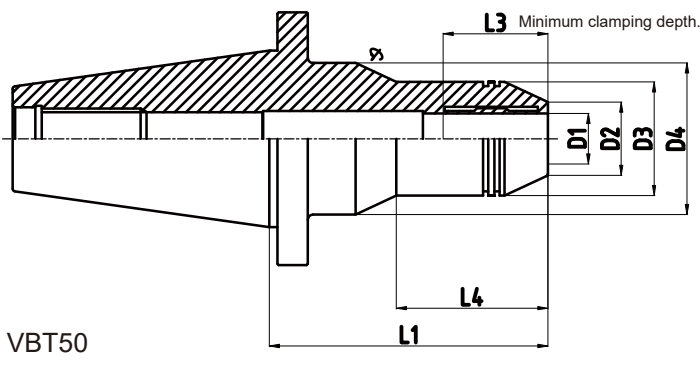

GRIND